

ROUND FOUNDATION

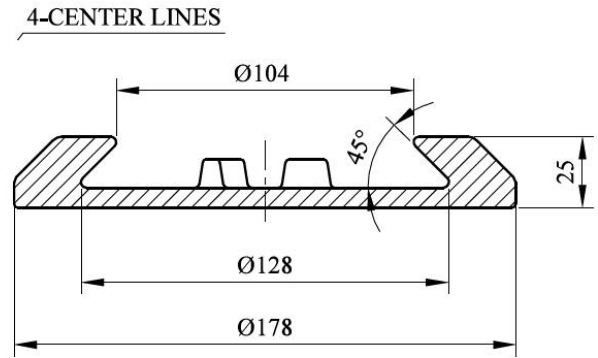
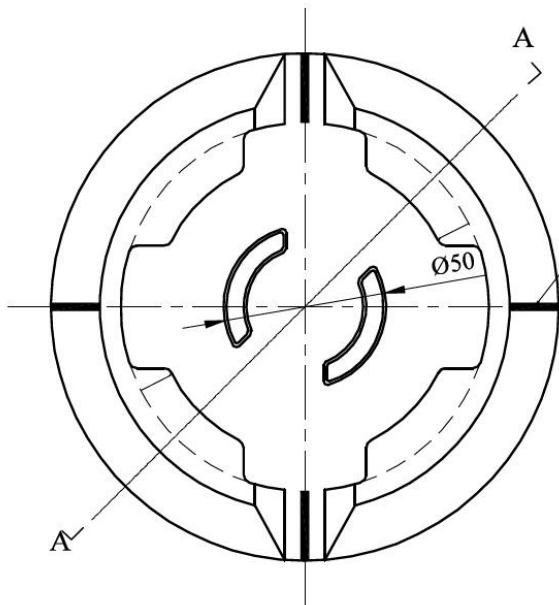

Material: Casting steel
Finish: Shop primer
Weight: 2.8kg

M.B.L:Tension: 500KN
M.B.L:Shear: 420KN
M.B.L:Compression: -